

Installation Instructions

Eibach Springs, Inc. • 264 Mariah Circle • Corona, California 92879-1751 • USA • Tech Support 800-222-8811 Ext 114

Eibach Load Leveling System #AK31-82-071-02-02

Note: This Eibach Load Leveling System is designed to be used on vehicles with 0-300 lbs. of additional weight in the rearward area of the truck. See the diagram and chart below for approximate heights with the preload collar set at full high with the corresponding weight.

Note: We do not recommend going past the full high measurement shown below.

Note: The Eibach Load Leveling System must not be used with the OE shocks. Extended travel shocks are required to avoid damage to the suspension.

Kit Contents	Description	Part Number	Qty
	Spring, Coilover	1200.375.0250S	2
	Housing, Threaded	8001373	2
	Collar, Preload	8001374	2
	Adapter, Helical Rise	8001260	2
	Adapter, Upper Spring Perch	8001271	2
	Mount, Bump Stop	8001300	2
	Bump Stop	BS880005	2
	Screw, Hex, M10-1.5 x 30	H13024742	2
	Screw, Hex, M8-1.25 x 35	H13155071	4
	Washer, Flat 8mm	H50025000	4
	Screw, Hex, M12-1.75 x 30	H13155542	2
	Nut, Nylock, M12-1.75	H63025500	2
	Washer, Flat M12	H50025200	2
	Adjustment Tool, 6mm	PDK.TOOL	2
	Instructions	AK31-82-071-02-02INST	1

NOTES: Read All Instructions Before Beginning Installation

- Only qualified mechanics experienced in the installation and removal of suspension components should perform this installation.
- Use of a hoist and screw jack is highly recommended and will substantially reduce installation time.
- Never work on or under a vehicle unless it is properly supported.

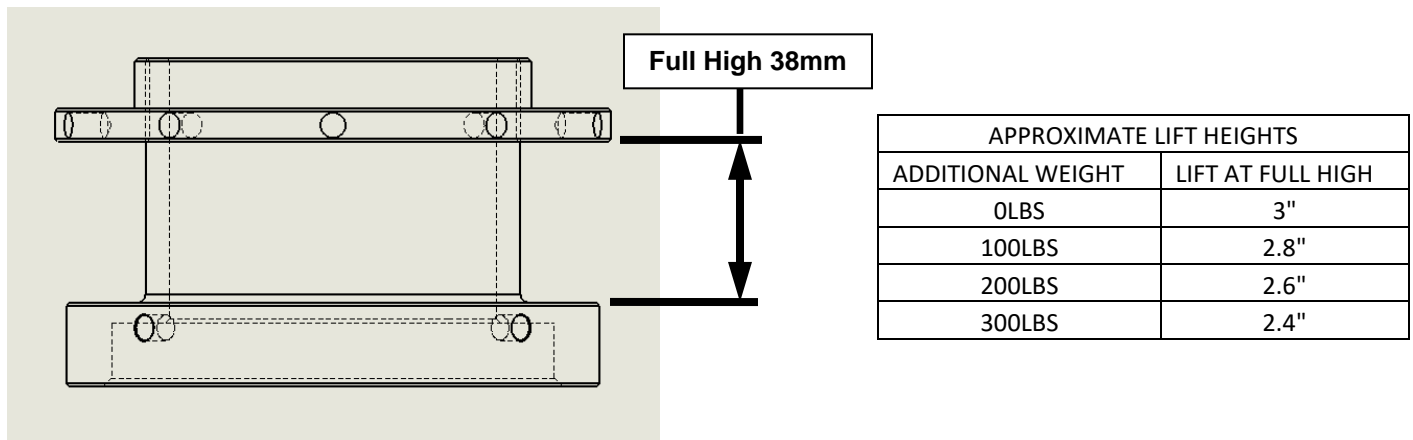

Eibach Load Leveling System Removal and Installation

1. Begin by raising the vehicle and supporting it with the proper safety equipment. **Note: Never work on or under a vehicle that is not supported by the proper safety equipment.**



Photo 1



Photo 2

2. Loosen and remove the screws that secure the OE bump stop to the chassis as shown, then, remove the bump stop. (See Photos 1 & 2)

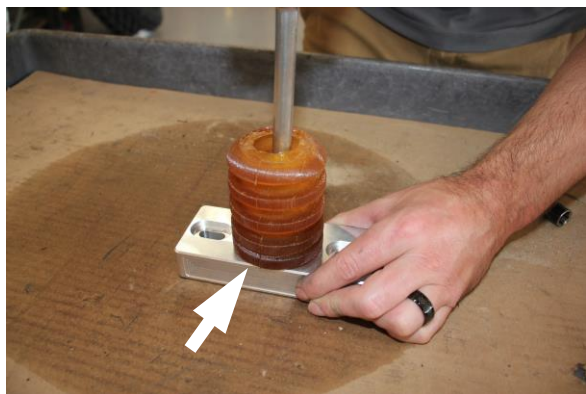

Photo 3

3. Use the M10-1.5 x 30mm L hex screws to secure the provided Eibach bump stop to the Eibach bump stop mount as shown. (See Photo 3)



Photo 4

4. Install the new bump stop assembly using the M8-1.25 x 35mm L hex screws and M8 flat washers as shown. (See Photo 4)



Photo 5

5. Use a screw or pole jack to support the rear axle as shown. (See Photo 5)

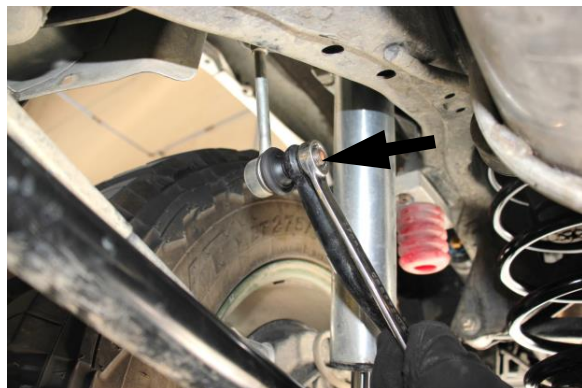

Photo 6

6. Disconnect the end link from the anti-roll bar as shown. (See Photo 6)



Photo 7



Photo 8

7. Loosen and remove the hardware that secures the lower shock mount to the axle, then, disconnect the shock from the axle. **(See Photos 7 & 8)**

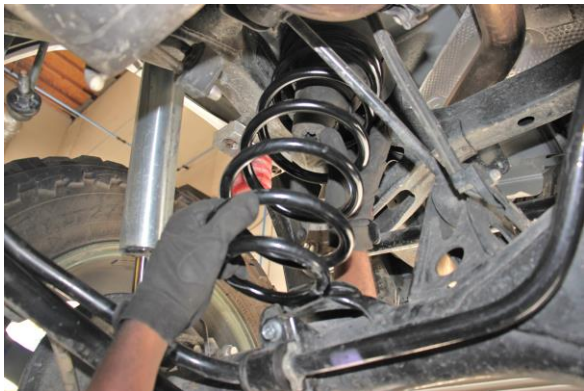

Photo 9

8. You can now lower the axle downward and remove the OE spring as shown. **(See Photo 9)**



Photo 10

9. Install the provided spring perch adapter and secure it with the M12-1.75 x 30mm hex screw, and M12 washer/nut. **(See Photo 10)**



Photo 11

10. Install the provided urethane adapter to the spring mount on the axle, lining up the helical rise on the adapter with helical rise on the axle as shown. **(See Photo 11)**



Photo 12

11. Install the adjustable spring perch assembly onto the urethane spring perch adapter on the axle as shown. **(See Photo 12)**

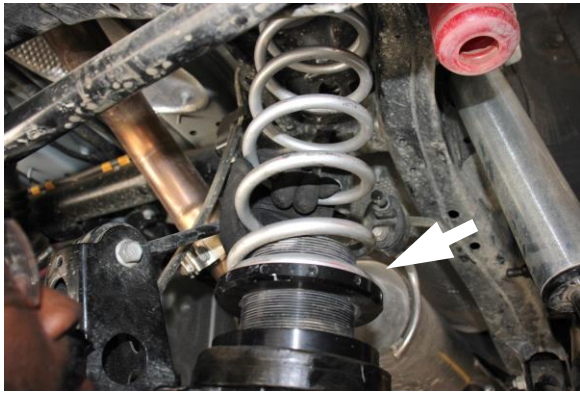

Photo 13



Photo 14



Photo 15

12. You can now install the Eibach spring into the vehicle and slowly raise the axle upwards making sure the top of the spring seats firmly into the upper spring adapter as shown. **(See Photos 13, 14 & 15)**



Photo 16

13. Secure the shock mount to the axle using the OE hardware as shown. **(See Photo 16)**



Photo 17

14. Reconnect the end link to the anti-roll bar with the OE hardware as shown. **(See Photo 17)**
15. Repeat this procedure on the opposite side.
16. Double check to make sure everything is properly positioned and tightened, then, road test the vehicle and re-torque if necessary.
17. After 500 miles of driving doublecheck and re-torque to make sure all hardware is still properly tightened as a safety precaution.